

- NOTE A: WHERE CURB AND GUTTER EXISTS, REMOVE AND RECONSTRUCT CURB AND GUTTER TO FIRST JOINT ON EITHER SIDE OF ENTRANCE.
- NOTE B: 1. FOR DRIVEWAYS SERVING ONE LOT THE MINIMUM WIDTH SHALL BE 10' WITH A MAXIMUM OF 20'.
 2. FOR DRIVEWAYS SERVING TWO OR MORE LOTS, THE MINIMUM WIDTH SHALL BE 16' PER SECTION 3.4.A.2.e OF THE ROAD ORDINANCE

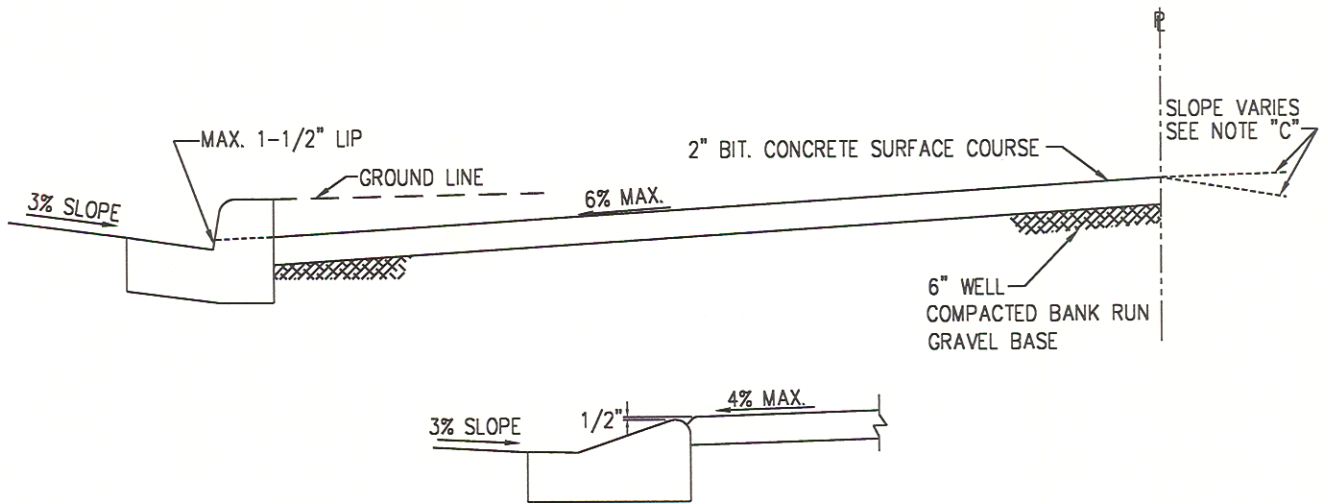

NOTE C: MAXIMUM GRADE OF PRIVATE DRIVEWAY OUTSIDE RIGHT-OF-WAY SHALL NOT EXCEED 15%.

CHARLES COUNTY GOVERNMENT

DEPARTMENT OF PLANNING & GROWTH MANAGEMENT

APPROVED:

[Signature]
 CHIEF OF DEVELOPMENT & CAPITAL SERVICES
 HIGHWAY ENGINEER

[Signature] 11/17/99
 DATE

STANDARD DETAIL
 RESIDENTIAL ENTRANCE
 CLOSED SECTION
 ROADWAY WITHOUT
 CONCRETE SIDEWALK

REVISIONS:

R
 2.34