

PLAN

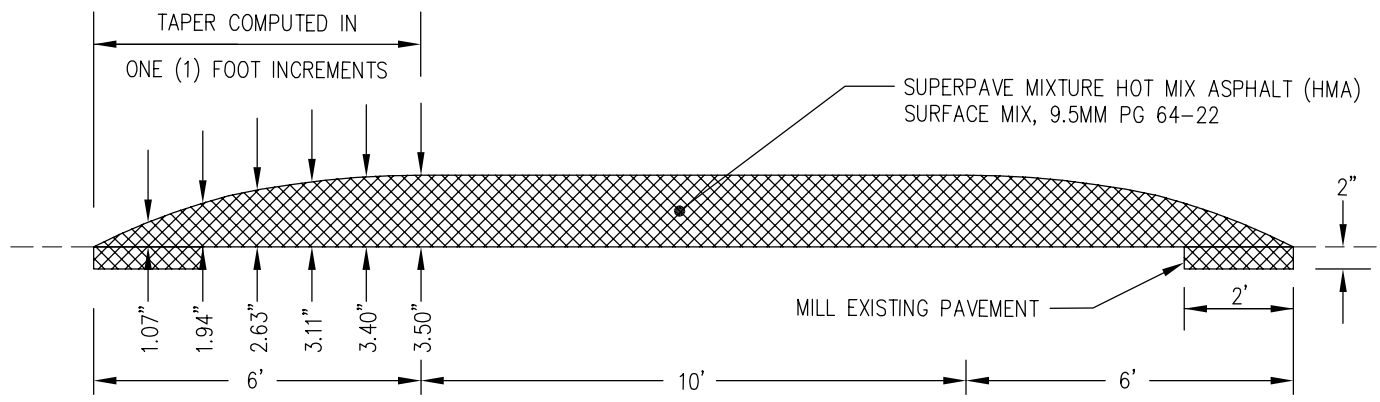

SECTION A-A

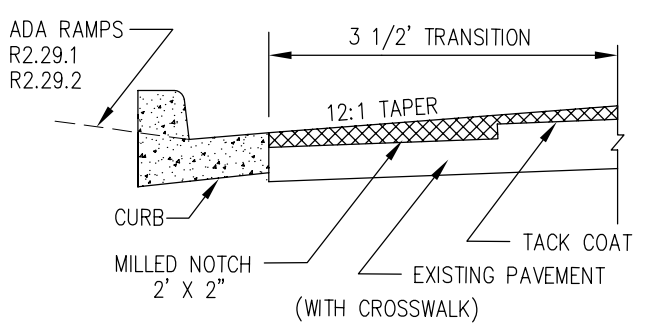

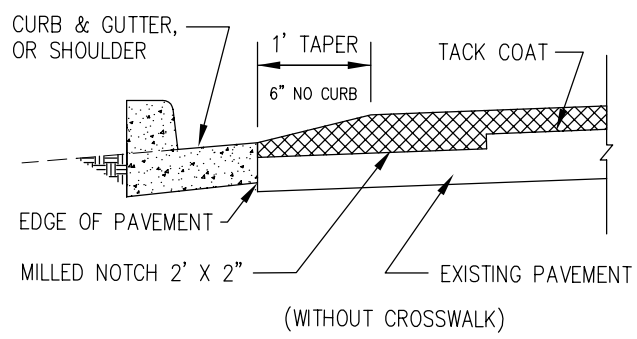

SECTION B-B

NOTES:

1. SEE LATEST EDITION OF MUTCD MANUAL FOR SIZE AND PLACEMENT OF SIGNS AND MARKINGS.
2. ADVANCED WARNING SIGNS SHALL BE PLACED IN EACH DIRECTION PRIOR TO A SERIES OF HUMPS AS DETERMINED BY THE COUNTY PER MUTCD.
3. PEDESTRIAN WARNING SIGNS & PLACARD SHALL BE BLACK ON FLOURESCENT YELLOW-GREEN BACKGROUND.

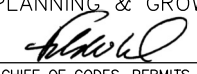
**CHARLES COUNTY GOVERNMENT**  
 DEPARTMENT OF PLANNING & GROWTH MANAGEMENT

APPROVED:  8/24/15  
 CHIEF OF CODES, PERMITS, & INSPECTION SERVICES DATE

 8/24/15  
 HIGHWAY ENGINEER DATE

STANDARD DETAIL

**TRAFFIC CALMING  
 SPEED HUMP**

REVISIONS:

R  
 2.52