

ELEVATION

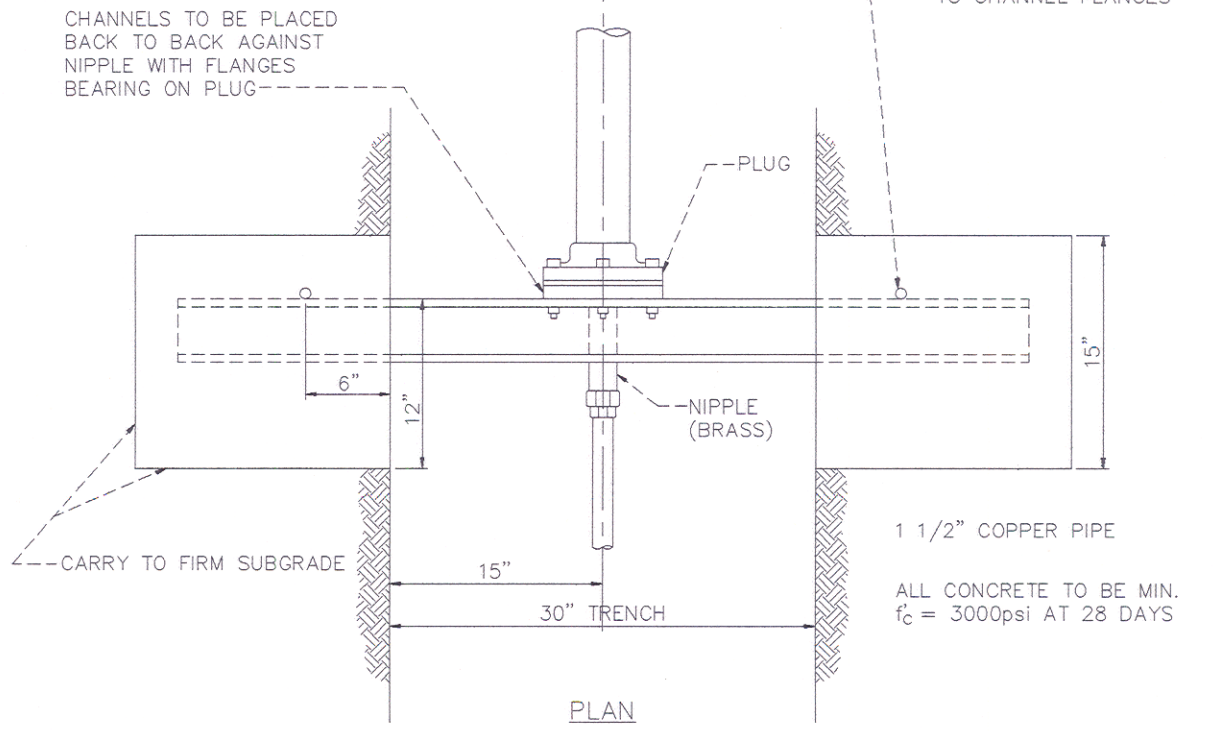

PLAN

NOTE:
 PAINT SOILS EXPOSED PARTS OF CHANNELS WITH TWO COATS OF BITUMINOUS PAINT.

CHARLES COUNTY GOVERNMENT
 DEPARTMENT OF PLANNING & GROWTH MANAGEMENT
 APPROVED: *[Signature]* 6/29/95
 DIRECTOR OF DEVELOPMENT SERVICES DATE
[Signature] 6/29/95
 WATER / SEWER ENGINEER DATE

STANDARD DETAIL
 METHOD OF
 BLOCKING PLUGS
 WHICH WILL BE
 TAPPED

REVISIONS:

B
 1.07

91